

Shaft Mount Speed Reducers

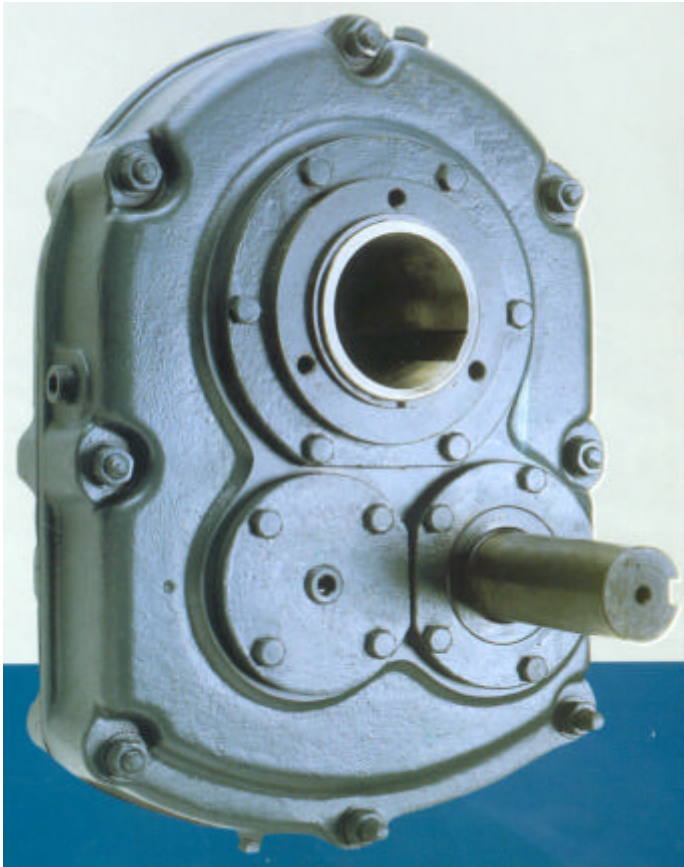

Design Features

Easy Installation

Simply insert the shaft key and slide the inboard bushing, reducer and outboard bearing onto the input shaft of your device. Then position and tighten the bushing mounting screws to complete the installation.

Easy Removal

The torque arm screws double as jacking screws, so no puller is required. Just remove the bushing mounting screws and insert them into the tapered holes in the bushing flanges. Once tightened, the reducer should slide easily off of the shaft.

Flexibility

Mounting versatility enables these torque arm reducers to be positioned anywhere along the driven shaft in horizontal, vertical and inclined positions for greater installation ease.

Heavy Duty Cast Housing

The cast, corrosion resistant, ductile iron housings are precision machined. A ribbed housing construction provides strong, rigid support for bearings and gearing. This design also channels oil to all bearings for superior lubrication and extended operating life.

Other Features

Double lip seals retain oil while locking out dirt.

Helical gear tooth design maximizes the power transfer efficiency.

Twin taper bushings eliminate play between the reducer and shaft. No set screws to score, mar, or gouge the shaft.

Twin tapered bushings make these reducers the optimal gearboxes for use on conveyors, mixers, and packing machinery.

The reducer mounts directly on the driven shaft, eliminating the need for a coupling or chain drive, sliding motor base, and support structure. There are no alignment problems.

Models/Sizes

315

325

415

425

515

525

615

625

Other Considerations

Bushings
and
Motor Mounts
also
Available

AGGREGATE EQUIPMENT SALES

3926 Irongate Rd Unit B
Bellingham WA 98226

Toll Free 1-866-755-5650 Ph: 360-756-6544 Fax: 360-650-1686

Speed Reducer and Motor Mount Dimensional Information

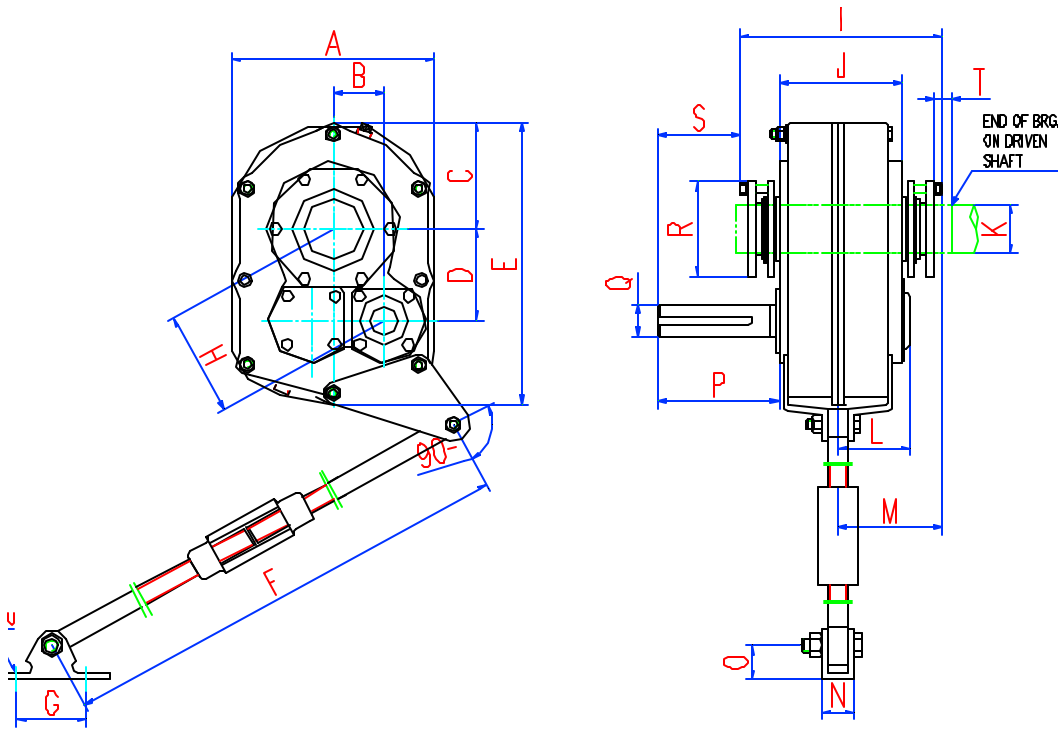

REDUCER DIMENSIONS

	3	4	5	6
A	9.25	10.38	13.13	15.13
B	2.33	2.76	3.04	4.09
C	4.84	5.50	6.56	7.56
D	4.17	4.79	5.67	6.73
E	12.88	15.13	18.31	21.31
F	26.94-32.94	29.19-35.19	29.19-35.19	29.19-35.19
G	3.00	4.00	4.00	4.75
H	4.78	5.53	6.43	7.88
I	9.22	9.98	10.52	11.53
J	5.63	6.13	6.31	6.88
K	2 3/16	2 7/16	2 15/16	3 7/16
L	3.30	3.14	4.45	4.57
M	4.52	4.79	5.05	5.73
N	1.25	1.44	1.44	2.75
O	1.06	1.75	1.75	2.00
P	4.34	5.57	5.74	6.08
R	4.38	4.81	5.63	6.13
S	2.34	3.44	3.44	3.73
T	1.50	1.75	1.81	1.81
U	0.44	0.50	0.50	0.63

Size 3	1.25 Diameter Shaft; .25 x .13 x 2.88 Keyed Shaft
Size 4	1.44 Diameter Shaft; .38 x .19 x 4.06 Keyed Shaft
Size 5	1.94 Diameter Shaft; .50 x .25 x 4.50 Keyed Shaft
Size 6	2.19 Diameter Shaft; .50 x .25 x 4.50 Keyed Shaft

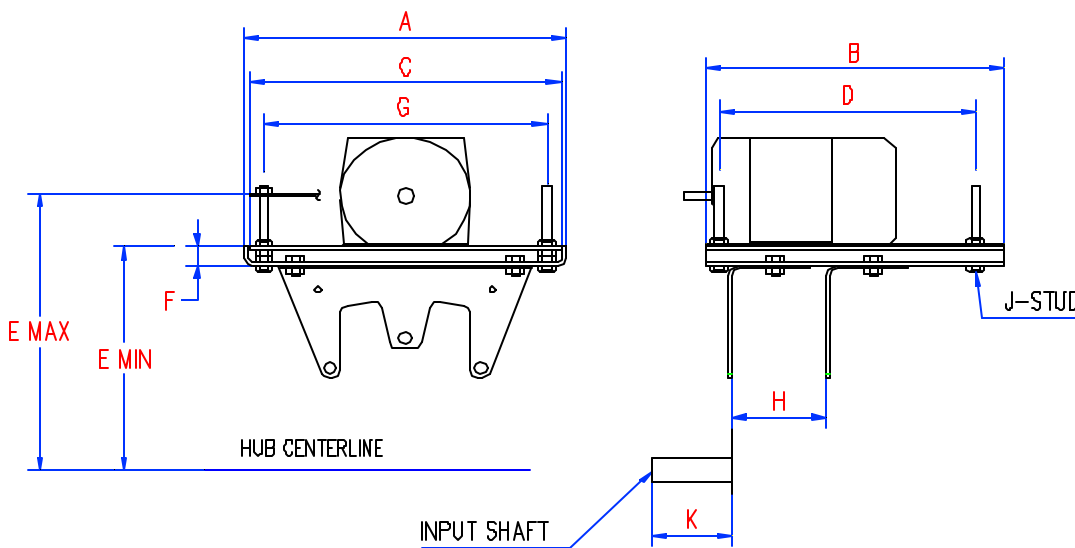

MOTOR MOUNT DIMENSIONS

	3	4	5	6
A	14.63	18.63	18.63	20.50
B	11.00	17.00	17.00	18.50
C	13.50	17.50	17.50	19.25
D	9.25	14.25	14.25	16.50
E	11.59-15.78	11.96-16.73	12.53-17.28	14.56-19.31
F	1.62	1.78	1.84	1.84
G	12.00	15.50	15.50	17.50
H	4.25	4.63	4.13	4.50
J	5/8 x 7	3/4 x 8	3/4 x 8	3/4 x 8
K	4.88	6.13	6.65	7.31

STANDARD BUSHING KITS

	1-15/16	2-3/16	2-7/16	2-15/16	3-7/16
Size 3	X	X			
Size 4		X	X		
Size 5			X	X	
Size 6				X	X